

General Safety Information

WARNING

- Before use, check the wheels to make sure that there are no bent or loose spokes, dents, scratches or cracks on the rim surface. Do not use the wheel if any of these problems are found.
- If the quick release mechanism is not used correctly, the wheel may come off the bicycle and serious injury could result. Read the Service Instructions for the quick release mechanism thoroughly before use.
- The wheel is designed for cross-country riding. Do not use it for downhill riding, otherwise the wheel may become bent or otherwise damaged, and accidents may occur as a result.
- Check that the wheels are fastened securely before riding the bicycle. If the wheels are loose in any way, they may come off the bicycle and serious injury may result.
- Obtain and read the service instructions carefully prior to installing the parts. Loose, worn, or damaged parts may cause injury to the rider. We strongly recommend only using genuine Shimano replacement parts.
- Specifications are available for dual disc brake and rim brake use, and also for disc brake use only (no rim brake braking surface). Do not use parts with specifications for disc brake use only with rim brakes, otherwise the brakes will not operate correctly.
- Be sure to carefully read the Service Instructions for the disc brakes also.
- Read these Technical Service Instructions carefully, and keep them in a safe place for later reference.

CAUTION

- The tires should be inflated to a suitable pressure before use.
- Use rim tape which can withstand high pressures, otherwise the tires may suddenly puncture and come off, and severe injury may result. Furthermore, it is not recommended that you reuse rim tape after it has been removed from the wheel. If the tape is reused, the tires may suddenly puncture and come off, and severe injury may result.

CAUTION

- Use of genuine Shimano spokes and nipples is strongly recommended.
- When using rim brakes, check that there are no pieces of metal or other foreign objects sticking to the brake shoes before riding the bicycle. If any such items are present, they may cause damage to the rim when the brakes are applied.
- When using rim brakes, it is not recommended that you use the brake shoes with the following product names with this product, because severe wearing of the braking surfaces of the rims may occur.
R55HC, M70T3, M70T2, M65T3, M65T, M55T, M50T
Furthermore, do not use brake shoes for carbon rims or ceramic coated rims either.

Note

- If the wheel becomes stiff and difficult to turn, you should lubricate it with grease.
- Do not apply any oil to the inside of the hub, otherwise the grease will come out.
- The hollow on the other side of the valve from the hole is a guide for indicating the wear of the rim. If this hollow is no longer visible, the rim is at the end of its useful life.
- We recommend that you ask authorized bicycle dealers to adjust the spoke tensions if there is any initial play in the spokes and after the first 1,000 km of riding.
- Spoke protectors are also sold separately. Use the CP-WH13 when using the CS-M760 (11-32T), and use the CP-WH12 for all other cassette sprockets.
- For maximum performance we highly recommend Shimano lubricants and maintenance products.
- Reflectors (manufactured by CATEYE) are also sold separately. Please ask your bicycle dealer for details.

Model number	Specification	Color
RR-550-WUW	CPSC	White
RR-550-WUA	AS	Amber
RR-317-WUA	DIN	Amber

- Parts are not guaranteed against natural wear or deterioration resulting from normal use.

Technical Service Instructions

SI-4CH0B

WH-M505

Wheel

In order to realize the best performance, we recommend that the following combination be used.

Applicable tire size	Clincher tire
	26 X 1.5 – 2.25
Largest sprocket	34T

This wheel can be used with 8-gear and 9-gear sprocket sets. Refer to the Product Technical Information for details on combination with other parts such as chains and cassette sprockets.

Specifications

Model number	WH-M505	
Rim size	26"	
Applicable spoke length	For front	254 mm
	For rear	254 mm
Rim width	25.2 mm	
Applicable brakes	V-BRAKE / Disc brake	Disc brake
	For dual V-BRAKE / disc brake use	For disc brake use only

Spoke lacing

Lace the spokes as shown in the illustration.

For front

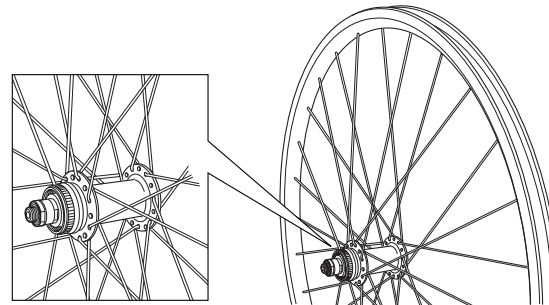

For rear

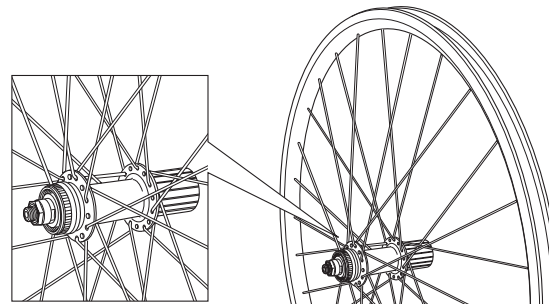

Spoke tension value

For front		For rear	
Right side	Left (rotor) side	Right (sprocket) side	Left (rotor) side
500 - 900 N (113 - 202 lbf)	900 - 1500 N (202 - 337 lbf)	900 - 1500 N (202 - 337 lbf)	500 - 900 N (113 - 202 lbf)

* These values should be used as a guide only.

Installation of the HG sprockets

For each sprocket, the surface that has the group mark should face outward and be positioned so that the wide parts of the gear projections on each sprocket and the A part (where the groove width is wide) of the freewheel body are aligned.

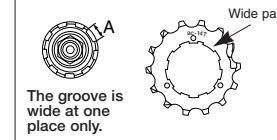

- For installation of the HG sprockets, use the special tool (TL-LR15) to tighten the lock ring.
- To replace the HG sprockets, use the special tool (TL-LR15) and TL-SR21 to remove the lock ring.

Tightening torque:
30 - 50 N·m
{261 - 434 in. lbs.}

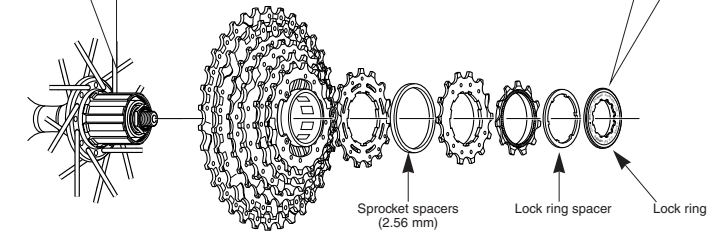
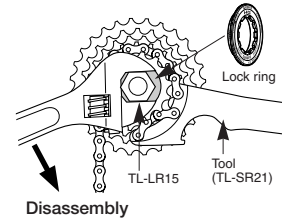

Replacement of the freewheel body

After removing the hub axle, remove the freewheel body fixing bolt (inside the freewheel body), and then replace the freewheel body.

Note

Do not attempt to disassemble the freewheel body, because it may result in a malfunction.

Tightening torque:
35 - 50 N·m {305 - 434 in. lbs.}

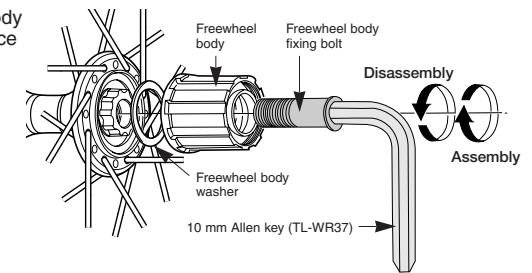

Installation of the rotor

Tightening torque:
40 N·m {350 in. lbs.}

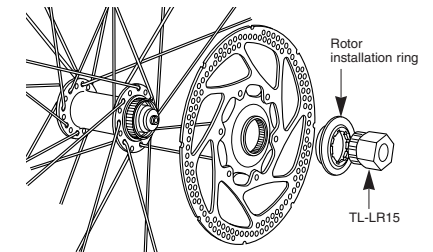

SHIMANO

SHIMANO AMERICAN CORPORATION
One Holland, Irvine, California 92618, U.S.A. Phone: +1-949-951-5003

SHIMANO EUROPE B.V.
Industrieweg 24, 8071 CT Nunspeet, The Netherlands Phone: +31-341-272222

SHIMANO INC.
3-77 Oimatsu-cho Sakai-ku, Sakai, Osaka 590-8577, Japan

Please note: specifications are subject to change for improvement without notice. (English)
© Feb. 2006 by Shimano Inc. XBC SZK Printed in Malaysia.